



Small volume: 0.53 m³ (18.7 cu.ft.).
Low working weight: 412 Kgs.
Great treatment capacity: 17.28 m³/day (4,565 usg/day).
Cost effective.
IMO MEPC 107(49) APPROVED.

Facet CPS 3.2E + EBM 14x1 bilge water separator is a device compact, adaptable to the small spaces available on board, lightweight and low maintenance. Its operation is very easy and completely automatic, with all its functions controlled through a PLC.

The presence of emulsified oil in the bilge water of the latest generation vessels caused IMO to issue the resolution MEPC.107(49), which requires that the resulting effluent after bilge water treatment must contain levels below 15 ppm of surfactants.

This model combines the classic coalescing plates Facet MPak® with the disposal membranes which achieve a high efficiency in the breakdown of chemical and mechanical emulsions.

This combination allows that Facet CPS 3.2E + EBM 14x1 Separator meets the strict requirements of the aforementioned IMO regulation.

Results

Facet CPS 3.2E + EBM 14x1 eliminates hydrocarbons in two stages. In the first stage, free hydrocarbon is separated from water through Facet coalescing plates, while in the second stage emulsions are broken by a membrane which removes emulsified hydrocarbon, reaching down an effluent with total hydrocarbon content of less than 5 ppm.

Standard Design Features

- Flow rate homologated: 0.73 m³/h (3.2 USGPM)
- Supplied ready to be installed
- No moving components other than pumps and pneumatic valves.
- Fixed control level, without float
- Very low maintenance, consisting in occasional hosing cleaning of the plates, and membrane replacement. No chemicals needed in both operations
- Water presence less than 5% in the separated oil, so it can be burned if required
- Power supply 380/440V, 50 or 60 Hz

Accessories

The equipment is supplied with the following accessories:

- Bilge alarm: as latest IMO MEPC. 107(49) resolution
- Electric heater in the oil dome to facilitate heavy oil discharge (if required)

Approvals

Facet CPS 10B MKIII + EMB has been tested, approved and certified according to the requirements of IMO MEPC.107(49).

Bilge Water Separators with Disposal Membrane CPS 3.2E + EBM 14x1

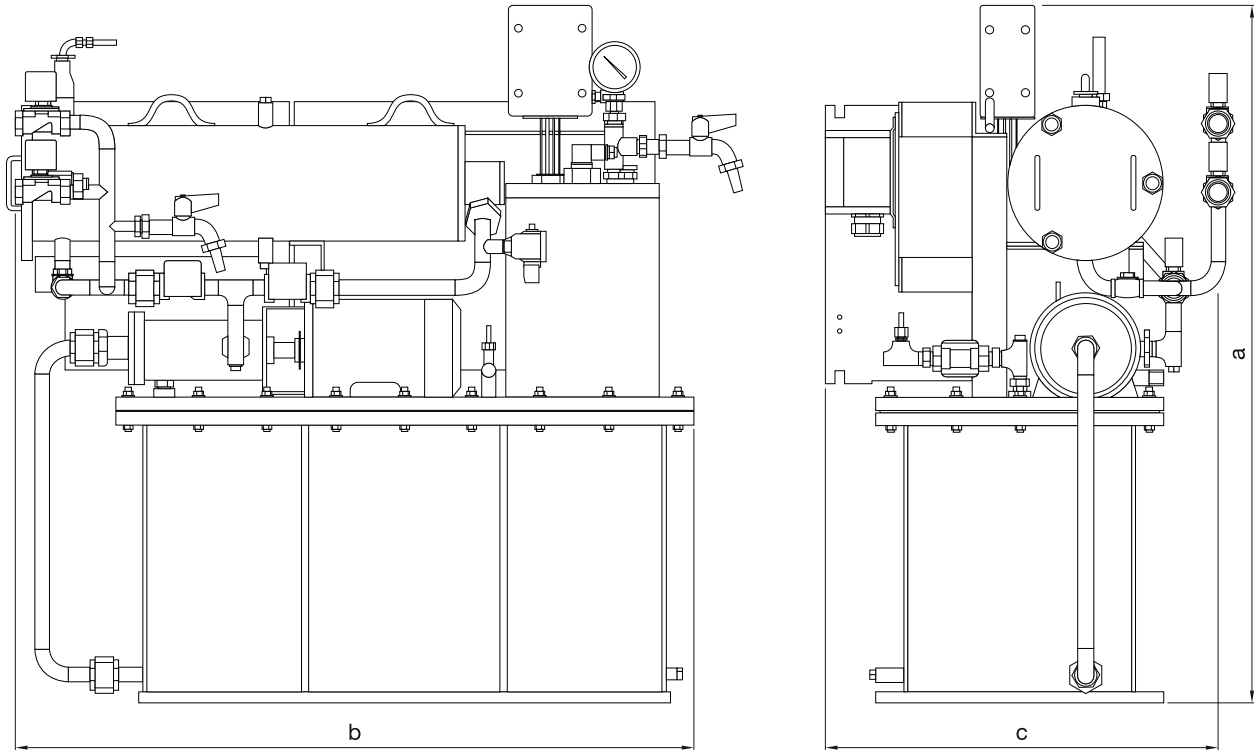

MODEL	DIMENSIONS						VOLUME		WEIGHT		WORKING WEIGHT	
	a		b		c		ft ³	m ³	lbs	kg	lbs	kg
	in	mm	in	mm	in	mm						
CPS 3.2E + EBM 14x1	39 ³ / ₈	1000	38 ¹ / ₂	980	22 ¹ / ₄	565	18.72	0.53	630	286	908	412

08082024

Bilge Water Separators with Disposal Membrane CPS 3.2E + EBM 14x1

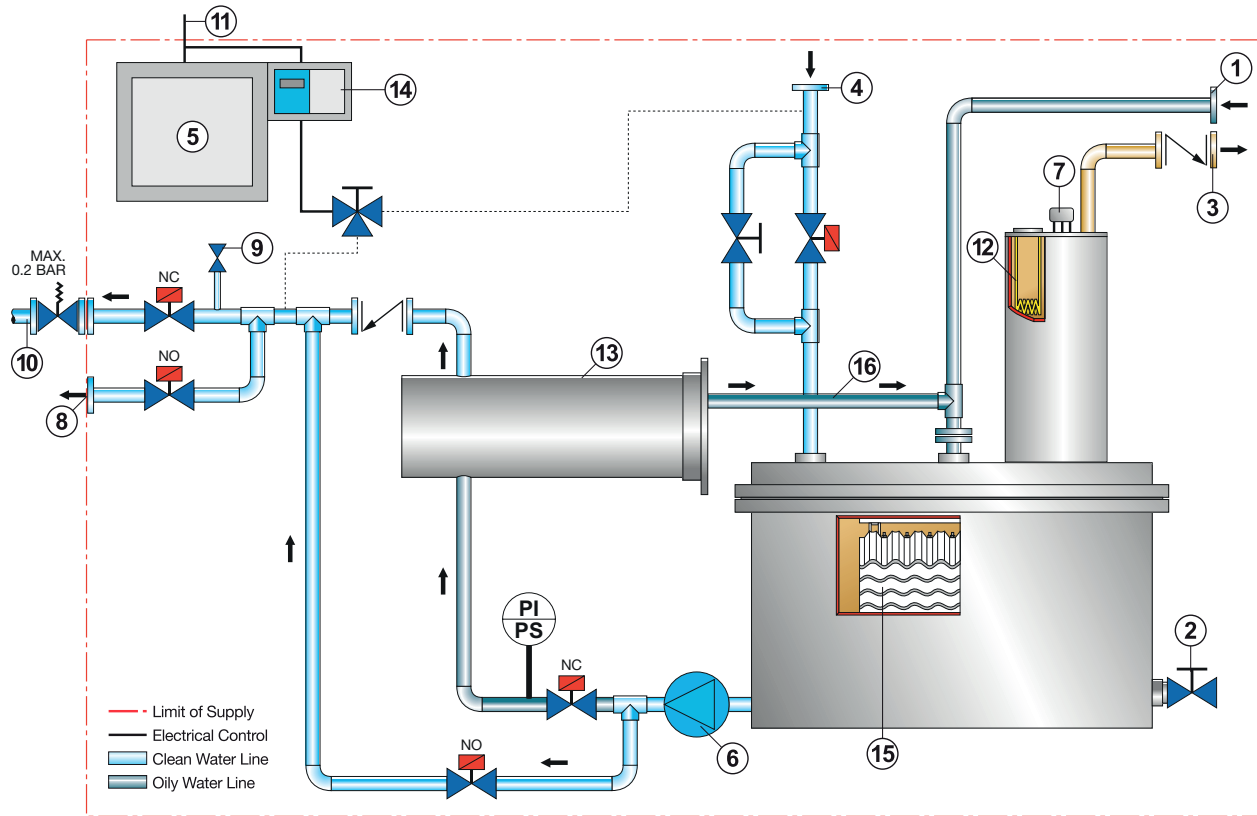

ITEM	DESCRIPTION
1	Oily water inlet line from bilge
2	Drain
3	Oil outlet
4	Clean water inlet
5	Control panel
6	Pump
7	Level control
8	Back to bilge line
9	Sample point
10	Overboard water outlet line
11	Electrical line (customer supply)
12	Heater (optional)
13	EBM 14x Separator module
14	PPM alarm & sensor
15	Facet MPak®
16	Oil return line